

FlaggerJoe Assembly Instructions

Item: FJ-UMB10 – Umbrella Only

- A = Umbrella Canopy
- B = Lower Umbrella Pole
- C = Double Flag Finial
- D = Flags (2)
- H = Carry / Storage Bag

- J = 24" Black PVC Post
- K = Rolling Base

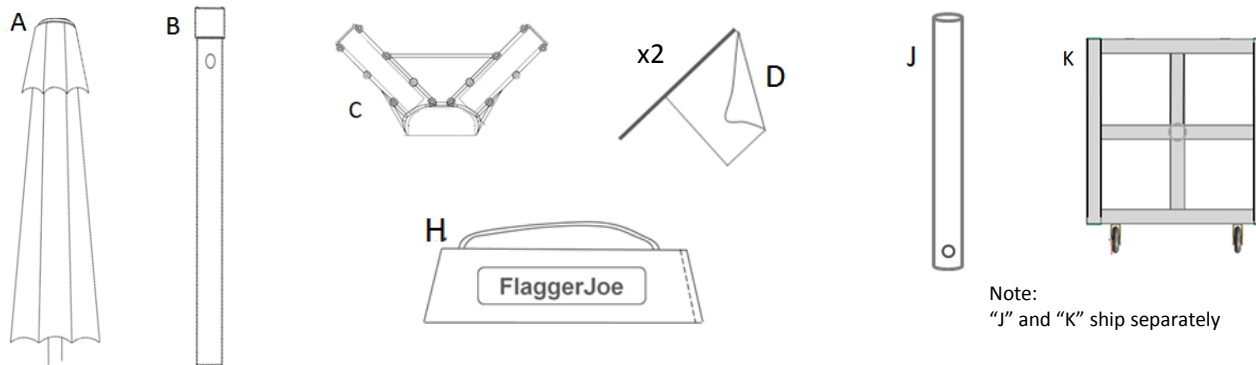

Note: 40lb Sand Bag/Weight required but not included

Questions: Call Customer Service at 888-329-3436

Step 1

Slide 24" black pvc post (J) into center post of rolling base (K). Line up hole in "J" with threaded knob. See figure 1

Step 2

Slide lower umbrella pole (B) into 24" black PVC post (J). Hand tighten threaded knob pictured in Figure 1.

Figure 1

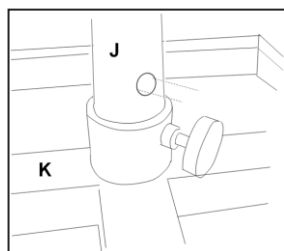

Step 3

Open umbrella canopy (A) – Slide pin into the highest position so the canopy is now open and secure. See Figure 2.

Figure 2

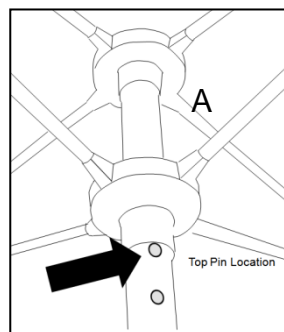

Step 4

Remove protective cap on the top of the umbrella canopy (A) and screw Double Flag Finial (C) into position.

Step 5

Insert both Flags (D) into Double Flag Finial (C) – Position flags properly.

Step 6

Connect umbrella canopy (A) with lower umbrella pole (B) by either lifting the umbrella off the ground and inserting the top pole into the bottom pole or move the rolling base over to the umbrella pole and connect while on the ground. Make sure button pops out of hole in the side of the lower umbrella pole (B)

Step 7

Stand the umbrella up.

Step 8

Inspect the double flags to make sure they are visible to oncoming traffic. If out of position, tilt the umbrella down and re-position by rotating "C". See Figure 3.

Figure 3

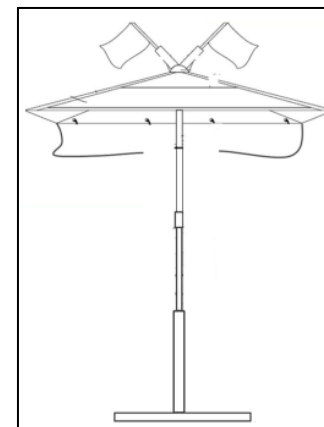

Finished Assembly

Step 9

Add 40lb Sand Bag/Weight to the Rolling Base.

Step 10

When job is complete, store parts and all other components in FlaggerJoe carry/storage bag (H).

NOTE: Intended Use Statement

Remove canopy when winds exceeds 10 – 15 miles per hour.
Never position the drop down sun flap towards oncoming traffic
When wind is present, never leave FlaggerJoe unattended

FlaggerJoe™

